

# LED COMBO LIGHT DM-EM119

## ■ ADVANTAGE

- ☞ Unique all inclusive lamp, reflector and lens assembly.
- ☞ High impact resistant.
- ☞ Internal back-up battery provides 90 minutes operation during a power outage.
- ☞ Long-lasting, energy efficient Red or Green LED EXIT sign illumination.
- ☞ Mounting: top mounted or wall mounted
- ☞ 5 years warranty.
- ☞ Applications: exit, hallways, doorways, etc.



## ■ DETAILS

### Features

- ☞ Injection-molded, engineering grade, 5VA flame retardant, high-impact, thermoplastic in white finish.
- ☞ High performance chrome-plated metallized reflector and plastic lens for optimal light distribution.
- ☞ Fully automatic solid-state, two rate charger initiates battery charging to recharge a discharged battery in 24 hours.
- ☞ Compact, low-profile design.

### Installations

- ☞ Universal knockout pattern on back plate for wall.
- ☞ EZ-snap thermoplastic mounting canopy included- provides top mounted.

### Certifications

- ☞ Comply with the requirements of the Standard(s) for Luminaires and are identified with the cETL Listed Mark.

### Accessories

- ☞ Screw and cap.
- ☞ Mounting fixing hardware
- ☞ Canopy

### Warranty

- ☞ All products from DIMILIGHT are guaranteed with 5 years' warranty.
- ☞ See [Warranty policy from DIMI LIGHT](#) for additional information.

## ■ DIMENSIONS

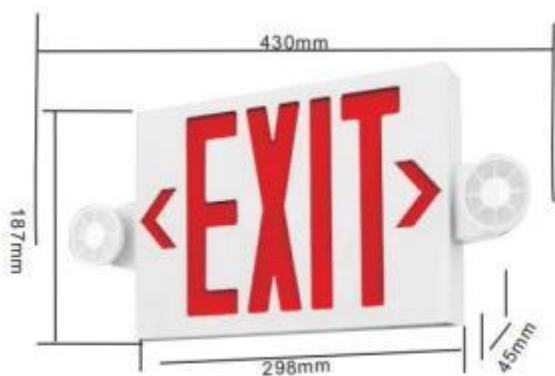

## ■ SPECIFICATION

	MODEL	WATT	INPUT VOLTAGE	EMERGENCY DURATION	CERTIFICATE
<input type="checkbox"/>	DM-EM119	5W	AC120V/277V	≥ 90 mins	cETLus& DLC Premium

## ■ ACCESSORIES

Screw and Cap

Fixing Hardware

Canopy



## ■ PACKING INFO

MODEL	14 PCS/CARTON	420PCS/PALLET		CONTAINER		
	DIMENSION(INCH)	N.W(LBS)	G.W(LBS)	20'GP(PCS)	40'GP(PCS)	40HQ(PCS)
DM-EM119	17.72" x15.35" x15.57"	21.2	39.9	379	731	921

## ■ WARNING

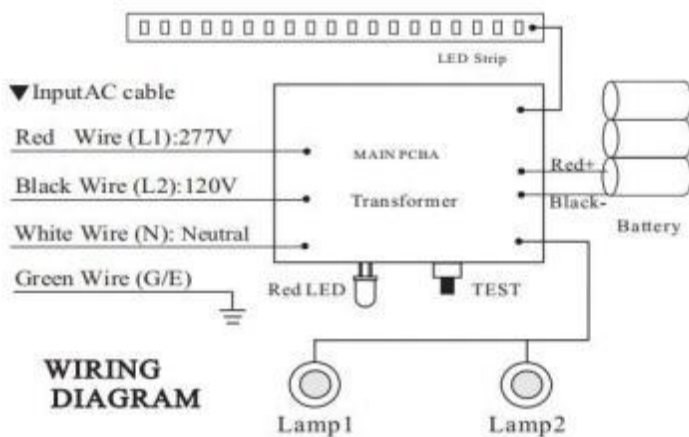

## ■ INSTALLATIONS

### ❖ Lamp heads

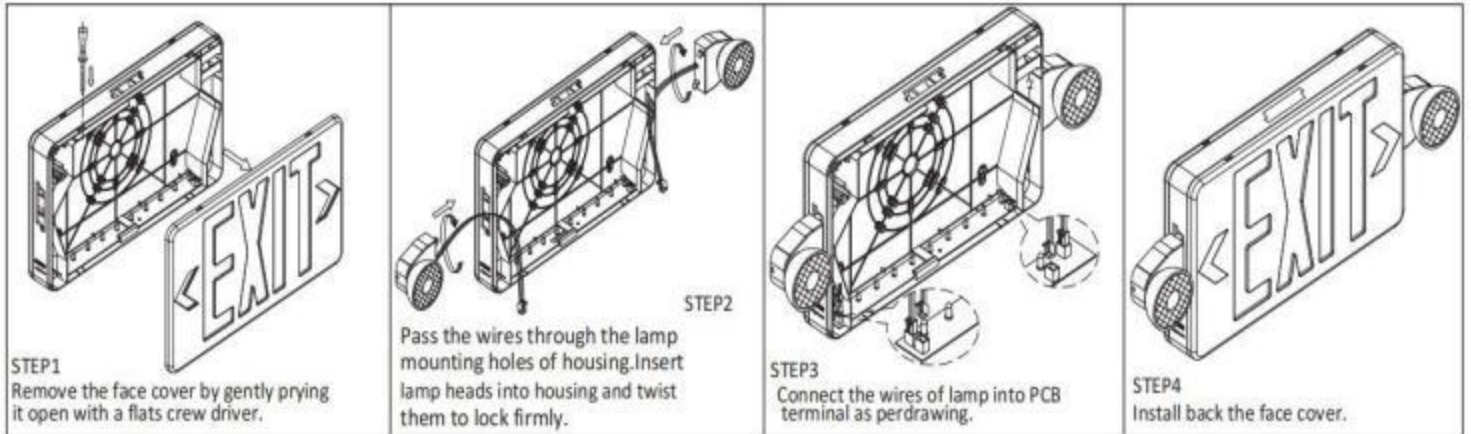

### ❖ Wall mount

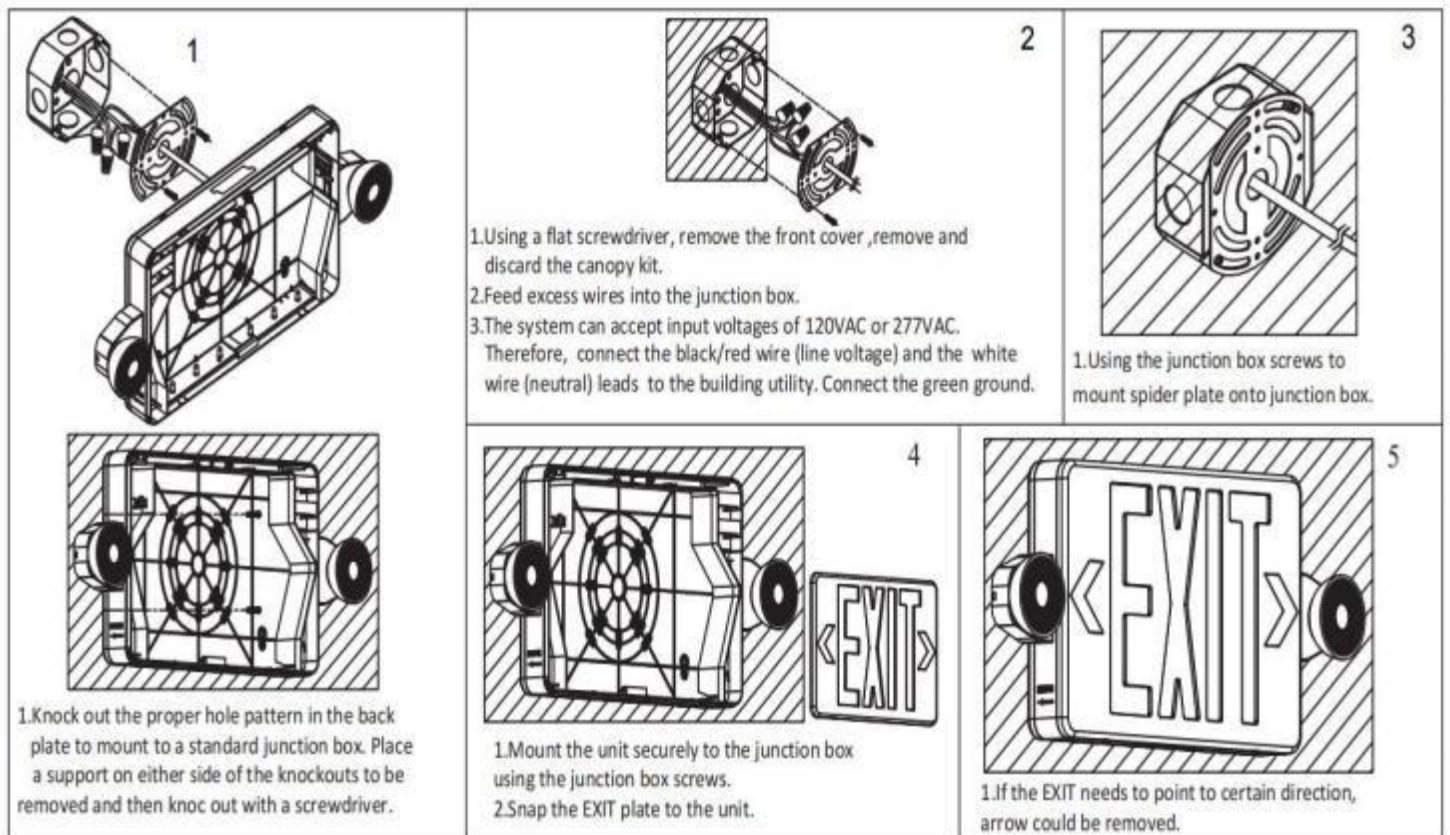

## ■ INSTALLATIONS

### ❖ Top mount

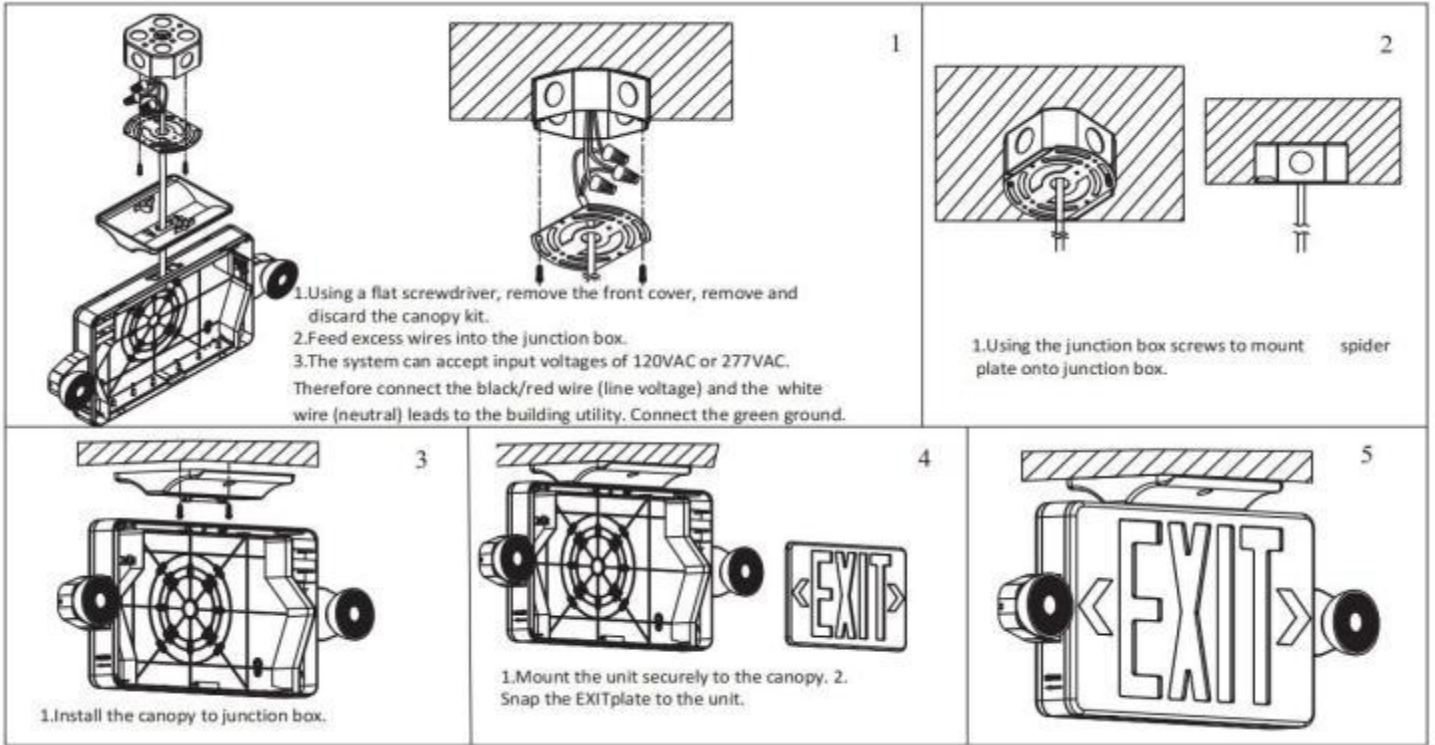

## ■ APPLICATION

